

# Locknuts

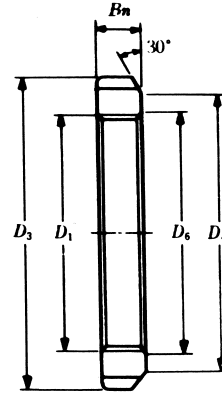
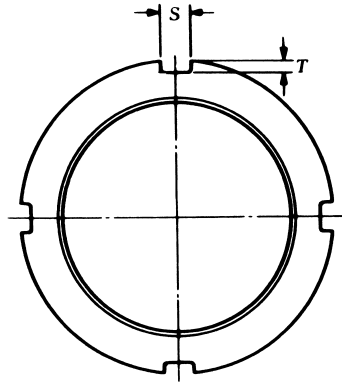

**HN**  
**HM**

Lock Nut Part No.	D 1 Thread <sup>1)</sup>	D 3 mm	D 4 mm	B n mm	S mm	T mm	D 6 mm	Weight (kgs)
HN 42	Tr 210 × 4	270	238	30	20	10	212	4.750
HN 44	Tr 220 × 4	280	250	32	20	10	222	5.350
HN 46	Tr 230 × 4	290	260	34	20	10	232	5.800
HN 48	Tr 240 × 4	300	270	34	20	10	242	6.200
HN 50	Tr 250 × 4	320	290	35	20	10	252	7.000
HN 52	Tr 260 × 4	330	300	35	24	12	262	8.550
HN 54	Tr 270 × 4	340	310	36	24	12	272	9.200
HN 56	Tr 280 × 4	350	320	36	24	12	282	10.000
HN 58	Tr 290 × 4	370	330	40	24	12	292	11.800
HN 60	Tr 300 × 4	380	340	40	24	12	302	12.000
HN 62	Tr 310 × 5	390	350	42	24	12	312.5	13.400
HN 64	Tr 320 × 5	400	360	42	24	12	322.5	13.500
HN 66	Tr 330 × 5	420	380	52	28	15	332.5	20.400
HN 68	Tr 340 × 5	440	400	55	28	15	342.5	24.500
HN 70	Tr 350 × 5	450	410	55	28	15	352.5	25.200
HN 72	Tr 360 × 5	460	420	58	28	15	362.5	27.500
HN 74	Tr 370 × 5	470	430	58	28	15	372.5	28.200
HN 76	Tr 380 × 5	490	440	60	32	18	382.5	33.500
HN 80	Tr 400 × 5	520	460	62	32	18	402.5	40.000
HN 84	Tr 420 × 5	540	490	70	32	18	422.5	46.900
HN 88	Tr 440 × 5	560	510	70	36	20	442.5	48.500
HN 92	Tr 460 × 5	580	540	75	36	20	462.5	55.000
HN 96	Tr 480 × 5	620	560	75	36	20	482.5	67.000
HN 100	Tr 500 × 5	630	590	80	40	23	502.5	69.000
HN 102	Tr 510 × 6	650	590	80	40	23	513	75.000
HN 106	Tr 530 × 6	670	610	80	40	23	533	78.000
HN 110	Tr 550 × 6	700	640	80	40	23	553	92.500

Note :

- 1) Tr means 30°, trapezoid thread and the digits are major diameter of thread and pitch。  
Tr 代表 30°，梯形螺紋；數字代表螺紋外徑及螺距。
- 2) The specifications of HN can be applied for HM。  
HN 的尺寸規格適用於 HM。