

SUS Locknuts

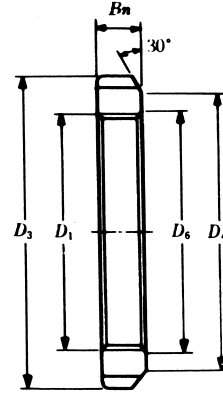
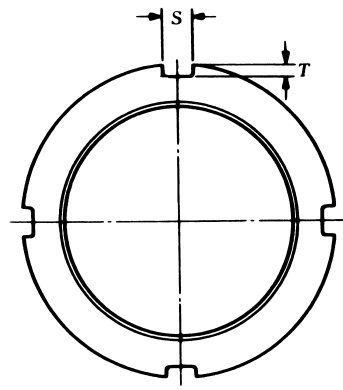

AN
KM

Lock Nut Part No.	D 1 Thread	D 3 mm	D 4 mm	B n mm	S mm	T mm	D 6 mm	Weight (kgs)	Lock Washer No.
AN 00	M 10 × 0.75	18	13.5	4	3	2	10.5	0.005	AW 00
AN 01	M 12 × 1.0	22	17	4	3	2	12.5	0.007	AW 01
AN 02	M 15 × 1.0	25	21	5	4	2	15.5	0.010	AW 02
AN 03	M 17 × 1.0	28	24	5	4	2	17.5	0.013	AW 03
AN 04	M 20 × 1.0	32	26	6	4	2	20.5	0.019	AW 04
AN 05	M 25 × 1.5	38	32	7	5	2	25.8	0.025	AW 05
AN 06	M 30 × 1.5	45	38	7	5	2	30.8	0.043	AW 06
AN 07	M 35 × 1.5	52	44	8	5	2	35.8	0.053	AW 07
AN 08	M 40 × 1.5	58	50	9	6	2.5	40.8	0.085	AW 08
AN 09	M 45 × 1.5	65	56	10	6	2.5	45.8	0.119	AW 09
AN 10	M 50 × 1.5	70	61	11	6	2.5	50.8	0.148	AW 10
AN 11	M 55 × 2.0	75	67	11	7	3	56	0.158	AW 11
AN 12	M 60 × 2.0	80	73	11	7	3	61	0.174	AW 12
AN 13	M 65 × 2.0	85	79	12	7	3	66	0.203	AW 13
AN 14	M 70 × 2.0	92	85	12	8	3.5	71	0.242	AW 14
AN 15	M 75 × 2.0	98	90	13	8	3.5	76	0.287	AW 15
AN 16	M 80 × 2.0	105	95	15	8	3.5	81	0.397	AW 16
AN 17	M 85 × 2.0	110	102	16	8	3.5	86	0.451	AW 17
AN 18	M 90 × 2.0	120	108	16	10	4	91	0.556	AW 18
AN 19	M 95 × 2.0	125	113	17	10	4	96	0.658	AW 19
AN 20	M100 × 2.0	130	120	18	10	4	101	0.698	AW 20
AN 21	M105 × 2.0	140	126	18	12	5	106	0.845	AW 21
AN 22	M110 × 2.0	145	133	19	12	5	111	0.965	AW 22
AN 23	M115 × 2.0	150	137	19	12	5	116	1.010	AW 23
AN 24	M120 × 2.0	155	138	20	12	5	126	1.080	AW 24
AN 25	M125 × 2.0	160	148	21	12	5	126	1.190	AW 25
AN 26	M130 × 2.0	165	149	21	12	5	131	1.250	AW 26
AN 27	M135 × 2.0	175	160	22	14	6	136	1.550	AW 27
AN 28	M140 × 2.0	180	160	22	14	6	141	1.560	AW 28
AN 29	M145 × 2.0	190	171	24	14	6	146	2.000	AW 29
AN 30	M150 × 2.0	195	171	24	14	6	151	2.030	AW 30

Note : 1) M means metric thread and the digits are major diameter of thread and pitch °

M 代表公制式螺紋；數字代表螺紋外徑及螺距。

2) SUS LOCKNUTS (不鏽鋼螺母)。

3) Material is SUS 304 (材質為 SUS 304)。